

**INSTALLATION GUIDE**  
**CARGO BARRIER**  
**'09 CHEVROLET TAHOE**

**Pro-gard**<sup>™</sup>  
PRODUCTS LLC.

STRONG | RELIABLE | SECURE

**pro-gard.com**  
**800.480.6680**

THESE COMPONENTS ARE REQUIRED  
TO INSTALL THE PRO-GARD BARRIER SYSTEM

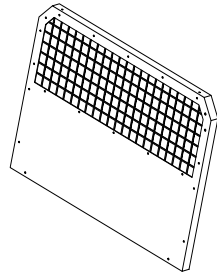

3B300WDT BARRIER

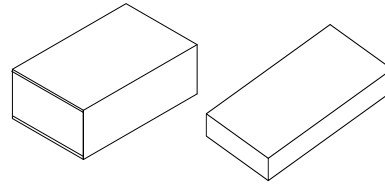

4B57T09 HARDWARE/WING KIT

I. Refer to the diagram on the last page of these instructions to verify all parts were received.

II. The following tools will be required to complete the installation.

- A. 1/4" drive ratchet with 7/16" socket
- B. Phillips Screwdriver
- C. Drill with 3/8" socket

III. Read all instructions carefully before starting the assembly process.

IV. Barrier Installation

- A. Install the upper mounting brackets (3P5731D Driver and 3P5731P Passenger) to the barrier using the phillips head bolts (3X36) and whiz nuts (3X16) through the holes in the top of the Barrier. Hand tighten only. See Fig. 1

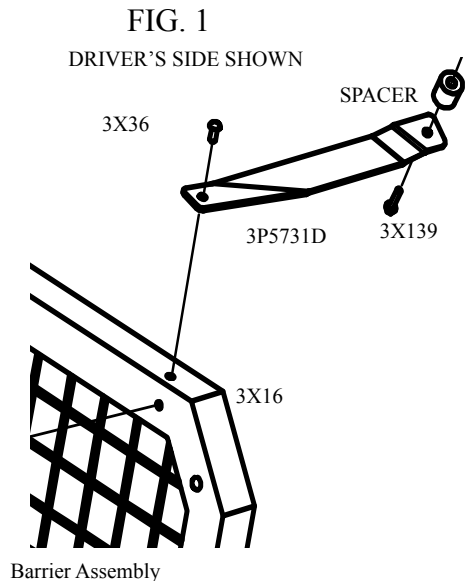

- B. Remove the rear OEM coat hook assemblies from the headliner.

C. Place the Cargo Barrier Assembly on the cargo floor behind the second row seats. Note: The bottom of the barrier should be aligned along the edge of the floor behind the second row seats. With the seats folded down begin to stand the Barrier up. While raising the Barrier swing the upper mounting brackets around toward the rear of vehicle. Align the upper mounting brackets with the coat hook mounting holes and secure loosely using the supplied M6 bolts and spacers. See Fig. 1

D. Attach the Polycarbonate top panel (3B572) to the Barrier using the existing bolts from the top of the barrier window frame. Hand tighten fasteners only. See Fig. 3

E. Attach the Polycarbonate Wings (3B571 Driver and 3B573 Passenger) between the Barrier and the interior trim using the Phillips head bolts (3X05A) and whiz nuts (3X16). Hand tighten fasteners only. See Fig. 3

F. Center the Barrier Assembly in the the vehicle.

G. With the top now supported, raise the second row seats in the vehicle, shifting the bottom of the barrier front to back to clear the back of second row seats as desired. Adjust the Polycarbonate wings for desired fit against the interior trim and headliner.

H. Secure the Barrier at the floor using the supplied 3X110 self-drilling screws I. Tighten all fasteners

J. Installation is now complete.

FIG. 2  
DRIVER'S SIDE SHOWN

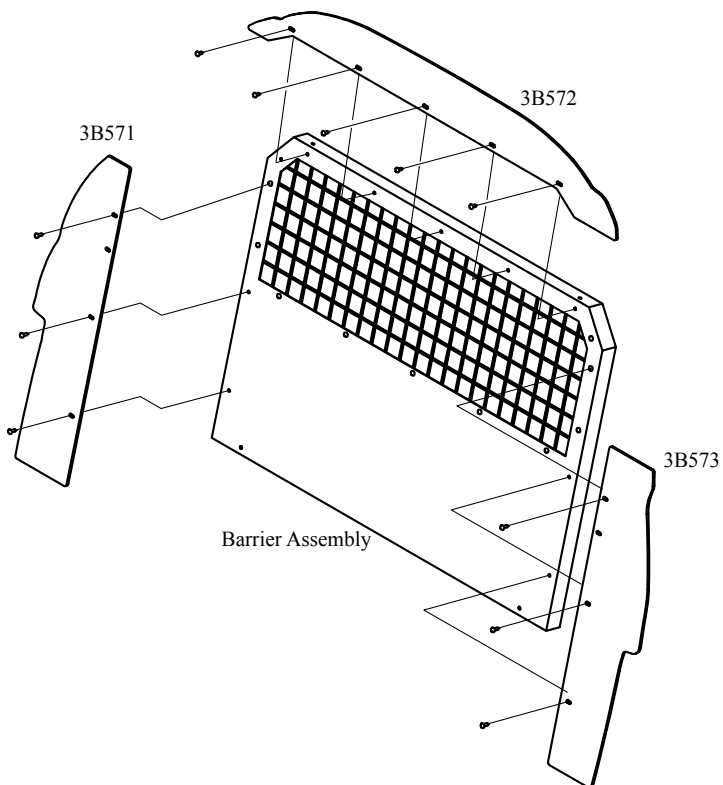
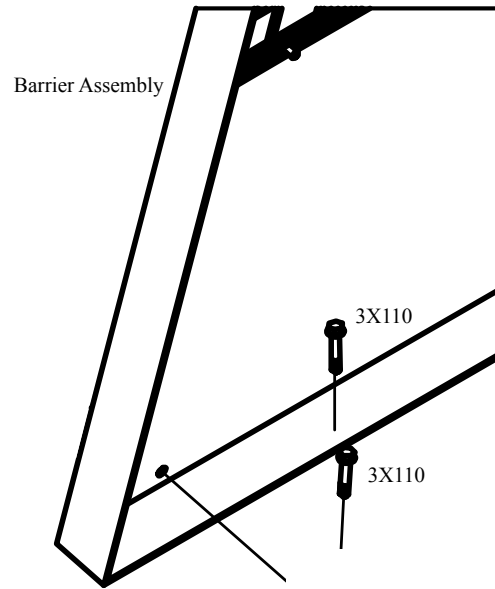

FIG. 3

FIG. 4

