

**INSTALLATION GUIDE**  
**STANDARD PARTITION**  
**2011 - CURRENT**  
**CHEVY CAPRICE**

**Pro-gard**<sup>™</sup>  
PRODUCTS LLC.

STRONG | RELIABLE | SECURE

**pro-gard.com**  
**800.480.6680**

THESE COMPONENTS ARE REQUIRED  
TO INSTALL THE PRO-GARD PARTITION SYSTEM

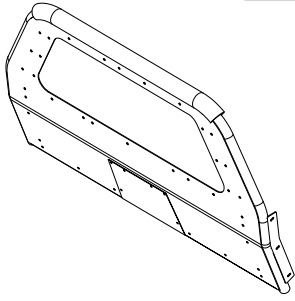

STANDARD PARTITION

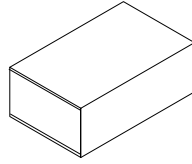

HARDWARE KIT

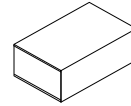

WING KIT

- I. Refer to the diagram on the last page of these instructions to verify all parts were received.
- II. The following tools will be required to complete the installation.

- A. 1/4" drive ratchet with 7/16" socket
- B. 3/16" Allen key
- C. 1" Hole saw
- D. Drill with 3/8" Socket
- E. T15 Torx Driver

- III. Read all instructions carefully before starting the assembly process.

**NOTE: Locate all Wiring, Fuel Lines, Brake Lines, and/or Cooling Lines before drilling holes or installing Fasteners.**

- IV. B-Pillar Bracket Installation

- A. Remove Center B-pillar trim on the Passenger-side.  
This will be reinstalled after bracket installation. (See Fig. 1)
- B. Place the Passenger B-pillar bracket (3PRT5311-01P)  
against the B-pillar face. (See Fig. 2).

- C. Orientate the B-pillar bracket so the bottom tab fits into the slot on the B-pillar and the formed edges wrap around the B-pillar. Push up on the Bracket until the tab is at the top of the slot. Using the supplied Self-Drilling screws (3X162) secure the B-pillar bracket to the vehicle b-pillar. (See Fig. 3)

**NOTE: It is critical that the seat belt strap be on the outside of the B-pillar bracket (See Fig. 3)**

- D. Using the Driver B-pillar bracket (3PRT5311-02D) repeat process on Driver-side of the vehicle.

FIG. 1  
PASSENGER SIDE SHOWN

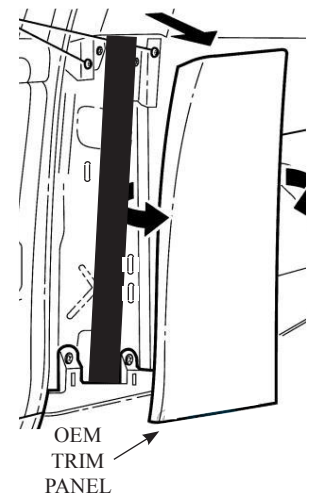
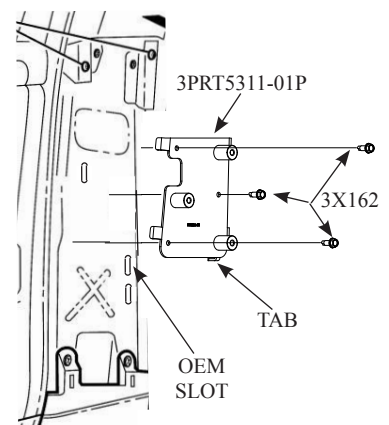

FIG. 2  
PASSENGER SIDE SHOWN



V. Drilling B-pillar Trim Panels

A. Carefully align the template per their included instructions. Using a 1” Hole Saw drill the clearance holes as marked on the template. Replacement of sound insulation is optional.

B. Replace the trim panel, insuring that the standoff’s protrude through the panel. (See Fig. 4)

C. Repeat process on the Passenger-side trim panel.

FIG. 3  
PASSENGER SIDE SHOWN

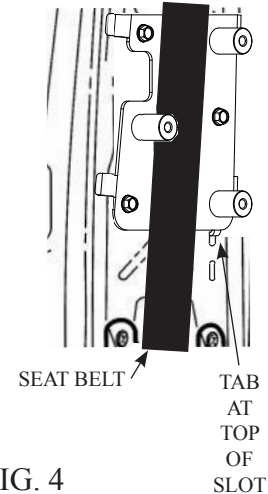

VI. Installing Partition Mounting Plates

A. Attach the Passenger-side Mounting Plate (3PRT5311-02P) using the supplied 5/16-18 x 3/4” Button head screws (3X149) to the Standoff’s protruding through the B-pillar trim (See Fig. 2). Hand tighten only.

B. Attach the Driver-side Mounting Plate (3PRT5311-02D) using the supplied 5/16-18 x 3/4” Button head screws (3X149) to the standoff’s protruding through the B-pillar trim (See Fig. 2). Hand tighten only.

FIG. 4  
DRIVER’S SIDE SHOWN

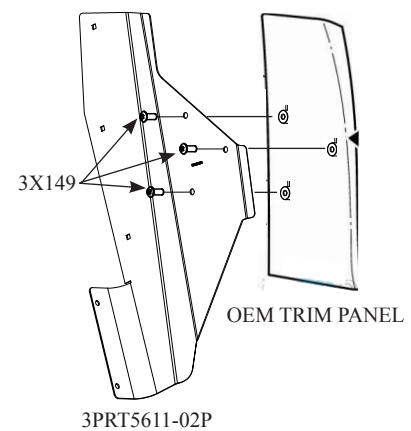

VI Partition Installation

A. Due to the weight and size of the partition, assistance from another party is highly recommended. Insert the partition into the vehicle, lift and position the partition so that it aligns with the Partition Mounting Plates, using the supplied 1/4-20 x 5/8” Carriage Bolts (3X36) and 1/4-20 Whiz nuts (3X16Z) secure the Partition to the Mounting Plates (See Fig. 3). Hand tighten only.

B. Audit the overall installation for fit and function of all components. Once satisfied, insure all fasteners are tight.

VII. Filler Wing Installation

A. The Filler Wings and their mounting hardware are packed in separate box marked Wing Kit. Install the Filler Wings according to their included Install Instructions.

VII. Seat Protector Installation *\*Optional Product*

A. The Seat Protector(s) and their mounting hardware are packed in separate box. Install the Seat Protector(s) according to their included Install Instructions.

FIG. 3  
DRIVER’S SIDE SHOWN

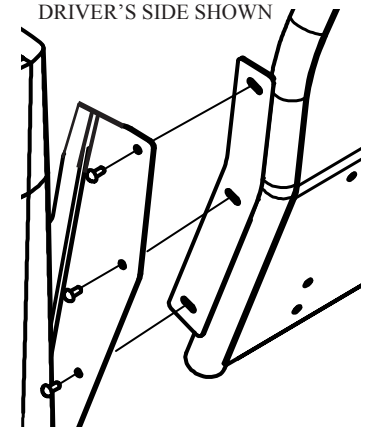

VIII. Installation is now complete.

PARTS LIST			
ITEM	QTY	PART NUMBER	DESCRIPTION
1	1	PRT5311-01	B-PILLAR BRACKET WELDMENT, DRIVER
2	1	PRT5311-02	B-PILLAR BRACKET WELDMENT, PASSENGER
4	1	PRT5311-03	B-PILLAR SHEET METAL, DRIVER
3	1	PRT5311-04	B-PILLAR SHEET METAL, PASSENGER
5	1	VARIES	PARTITION ASSEMBLY
6	6	3X149	5/16-18 X 3/4 BSHCS, BK
7	6	3X92	1/4-20 X 5/8 CARRIAGE BOLT
8	6	3X16Z	1/4-20 WHIZ NUT
9	6	3X162	1/4x3/4 SELF DRILLING SCREW
10	1	3SP5311-01	*OPTIONAL - STANDARD LOWER EXTENSION PANEL
11	1	3RP5311-01	*OPTIONAL - RECESSED PANEL
12	1	3SP5311-02D	*OPTIONAL - SPLIT LOWER EXTENSION - DRIVER
13	1	3SP5311-02P	*OPTIONAL - SPLIT LOWER EXTENSION - PASSENGER

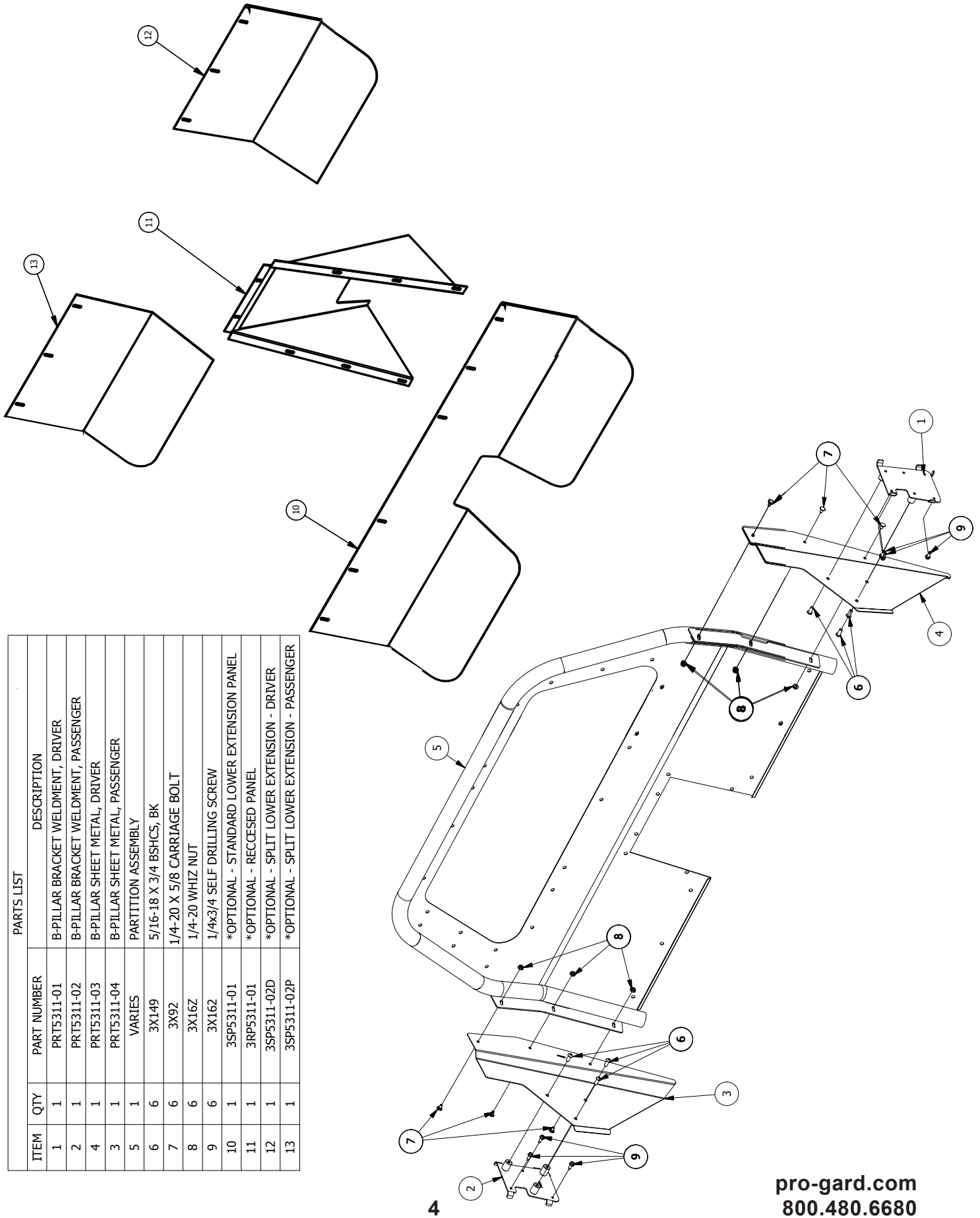



# DRIVER

CUT OUT CROSS HATCHED AREAS  
AND ALONG DASHED LINES

CENTER PUNCH 3 HOLE LOCATIONS  
THRU TEMPLATE & DRILL/CUT 1"  
DIA. HOLE

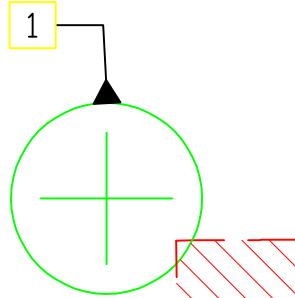

LINE UP CUT OUTS WITH  
TABS ON TRIM PANEL

View from rear of  
B-Pillar Trim

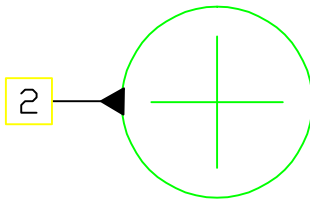
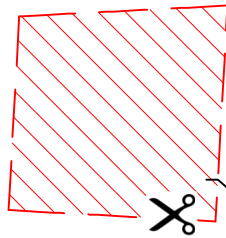

TRIM 1/8" OFF  
TOP OF THIS TAB



CHECK SCALE

SELECT "NONE" FOR PAGE  
SCALING WHEN PRINTING  
FROM .pdf FILE

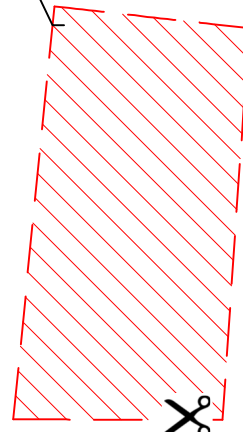
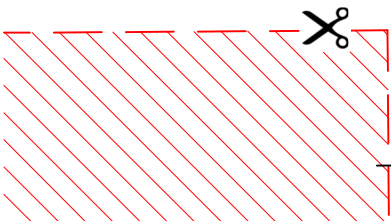
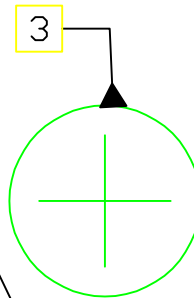
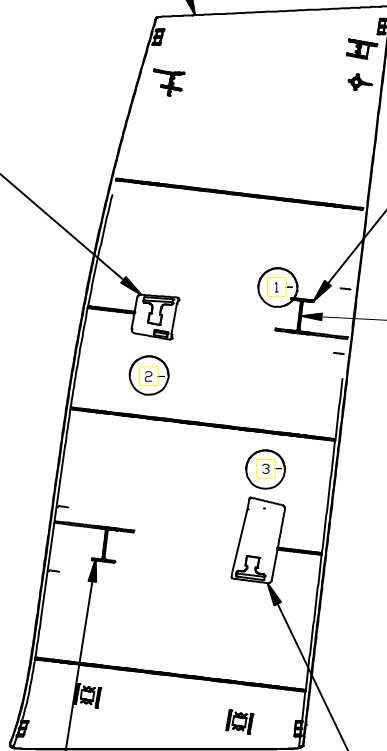



**CUT OUT CROSS HATCHED AREAS  
AND ALONG DASHED LINES**

# PASSENGER

