

INSTALLATION GUIDE

PUSH BUMPER

PB81FT09

'09 FORD F150 4-DOOR

'09 FORD EXPEDITION

Pro-gard[™]
PRODUCTS LLC.

STRONG | RELIABLE | SECURE

pro-gard.com
800.480.6680

THESE COMPONENTS ARE REQUIRED
TO INSTALL THE PRO-GARD PUSH BUMPER SYSTEM

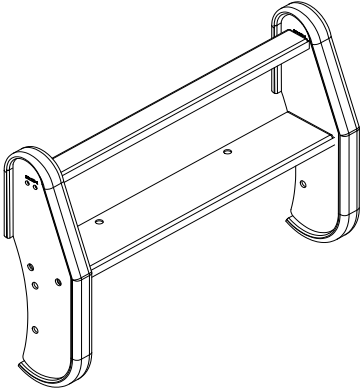

3E1106
PUSH BUMPER FRONT FACE

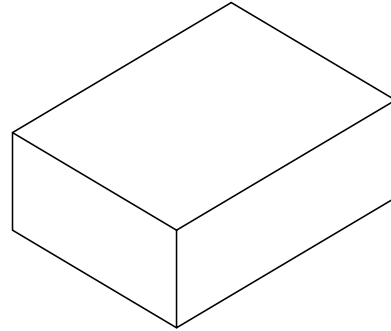

4PB81FT
MOUNTING KIT

- I. Refer to the diagram on the last page of these instructions to verify all parts were received.
- II. Tools Required:
 - A. 15mm socket wrench (1/2" drive preferred)
 - B. 3/4" combination wrench and socket wrench (1/2" drive preferred)
- III. Read all instructions carefully before beginning the installation process.
- IV. Removal of OEM Front Tow Hooks.
 - A. Locate and remove the OEM front tow hooks from the front of each frame rail by removing two bolts from below on each side.
 - B. Keep the bolts and nut assemblies nearby for reinstallation.
- V. Installing the push bumper mounting brackets.
 - A. Orient the Mounting Brackets near the front of the vehicle as shown in fig 2.
 - B. Place the Mounting Bracket against the bottom of the corresponding frame rail and attach using the OEM bolts and nuts. Leave bolts loose for alignment with the front section of the Push Bumper system.

Note: The large gusseted flange goes to the front and toward the center of the truck.

C. Repeat for other side

VI. Installing Push Bumper Front Section (3E1106).

A. Assemble Push Bumper Front Section (#3E1106 packaged separately) per instructions.

B. Once assembled, place it around the outside of the two mounting brackets and attach with four black 1/2" bolts, lock washers, and nuts supplied with the Front Section.

C. Tighten the 1/2" bolts just installed.

VII. Tighten the bolts under the front of the frame rails. Installation is complete.

FIG 1.

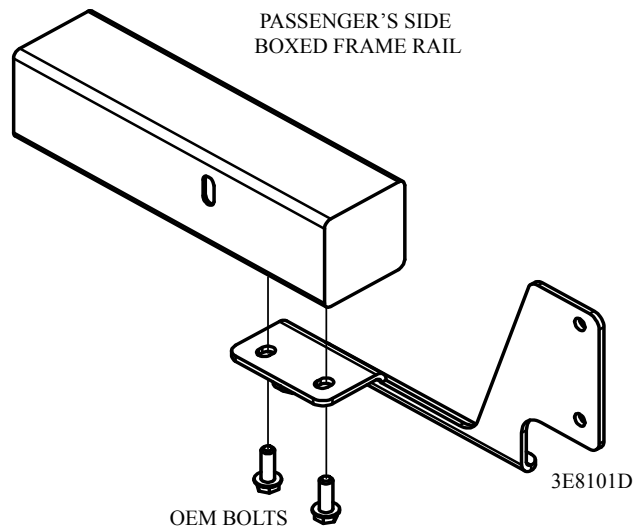

FIG 2.

