

**INSTALLATION GUIDE**  
STANDARD PARTITION  
FORD EXPLORER

**Pro-gard**<sup>™</sup>  
PRODUCTS LLC.

STRONG | RELIABLE | SECURE

**pro-gard.com**  
**800.480.6680**

THESE COMPONENTS ARE REQUIRED  
TO INSTALL THE PRO-GARD PARTITION SYSTEM

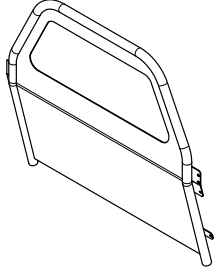

P4700EXPL SERIES  
STANDARD PARTITION

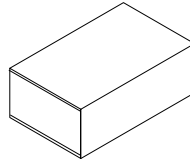

4K47EXPL07  
HARDWARE KIT

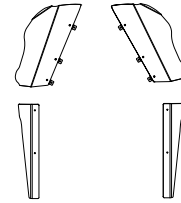

W47EXPL07A  
WING KIT

- I. Refer to the diagram on the last page of these instructions to verify all parts were received.
- II. The following tools will be required to complete the installation.
  - A. 1/4" drive ratchet with 7/16" socket
  - B. 3/8" drive ratchet with 15mm socket
- III. Read all instructions carefully before starting the assembly process.

IV. Partition Installation

A. Assemble the 3P60 Foot Mounting Plates to the bottom of the 3P425 Mounting Foot Brackets, inserting the 3P36 (5/8") carriage bolts through the Plate first and up through the holes in the foot so the 3X16Z whiz nuts thread on at each side of the weld. (See fig. 1)

B. Remove the outside OEM seat mounting bolts/nuts at the rear of both front seats so the Foot Mounting Plate Assemblies can slide under the seat frame. Align holes and reinstall the OEM bolts/nuts. Leaving loose to allow adjustment later.

C. Slide a 3P540 (3") PVC spacer over each of the tubular mounting feet. (See fig. 1)

D. With the help of another person, place the partition in the rear seat of the vehicle with the window latch side facing up. Begin to stand the partition up and slide the roll bar portion of the partition down over the tubular mounting feet. Be sure the partition slides down and rests on the PVC spacers. Roughly center the partition in the vehicle.

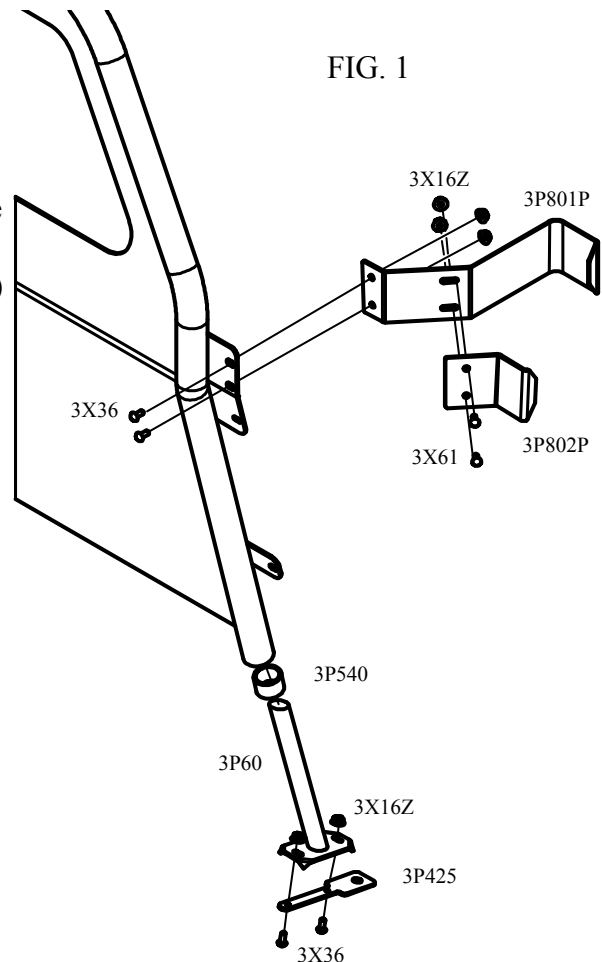

E. Install one B-pillar Bracket by placing the B-pillar Brackets in through the front doors between the seat belts. Slide the rear flange of the b-pillar bracket (with 2 round holes) over the top and behind the upper partition tab. Pull the partition and b-pillar bracket forward until the front flange of the bracket will swing out and hook around the front of the b-pillar and engage the rubber door seal strip. Make sure the seat belts are not pinched and run freely. Align with two slots in the partition tab and loosely fasten with two 3X36 (5/8") carriage bolts and 3X16Z whiz nuts. Repeat on other side. (See fig. 1)

F. Center the partition by measuring at the b-pillar. Tighten the OEM seat mounting bolts/nuts.

G. Locate the B-pillar Clamps against the outside of each B-pillar Bracket so they engage the rubber door seal strip. Attach using 3X61 (3/4") carriage bolts and 3X16Z whiz nuts. Slide the bolts forward in the slots to yield a good clamping action and tighten. (See fig. 1)

H. Tighten the bolts at the rear of the B-pillar Brackets to secure the partition.

I. The Filler Wings and their mounting hardware are packed in separate box marked W47EX PL07A Wing Kit.

1. Attach all six 3P928 Wing Mounting Brackets to the 4W47A series Upper Wings by placing the long leg of the bracket against the inside surface of the wing so the bracket wraps around the edge of the wing. Start the 3X92 (1/2") bolts from the opposite side of the wing and out through the bracket so the 3X16Z nut will tighten against the bracket. (See fig. 2)

2. When complete, mount the assemblies to the front side of the partition with the remaining 3X92 bolts and 3X16Z nuts. Two of the mounts on each side utilize two of the window frame mounting bolts, remove and reinstall these nuts. Be sure the wing is free to flex inward toward the center of the vehicle. (See fig. 2)

3. Install the 4W47B Lower Wings on both sides of the vehicle using two 3X36 (5/8") carriage bolts and 3X16Z whiz nuts to secure each. (See fig. 2)

J. Check the overall installation for fit and function of all components. Be sure all fasteners are tight.

K. Installation is complete.

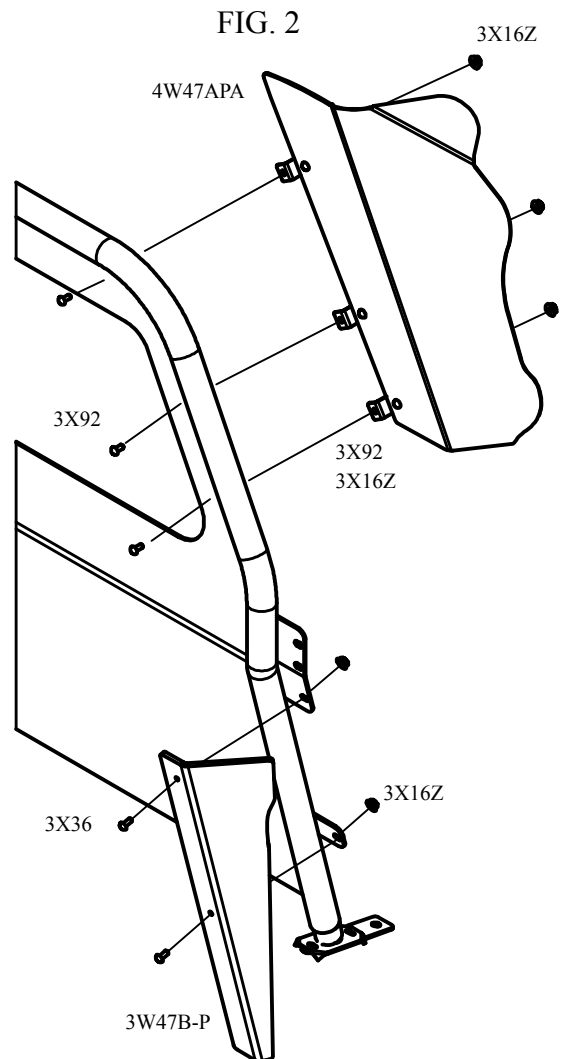

FIG. 3

